

**TREATMENT PLANT APPROVAL 01/2022**  
**Amendment 1**  
*Plumbing and Drainage Act 2018*

**Approval**

1. The **Nature Clear GWS10** (“the system”) described in the Specifications and Drawings in the attached Schedule and manufactured by **Ecoflo Wastewater Management Pty Ltd** (“the manufacturer”) (ABN 33 606 583 895) has been assessed in accordance with the Queensland Plumbing and Wastewater Code (QPW Code) dated 26 October 2017.
2. Approval is granted for a greywater treatment system, subject to compliance by the manufacturer with the requirements of the *Plumbing and Drainage Regulation 2019* and the conditions of approval detailed below.
3. This approval, the conditions of approval and the Schedule comprise the entire Treatment Plant Approval document.
4. Any modification by the manufacturer to the design, drawings or specifications scheduled to this approval must be approved by the Chief Executive.

**Conditions of approval**

5. The manufacture, installation, operation, service and maintenance of the systems must be in conformity with the conditions of this Treatment Plant Approval.
6. The greywater treatment system may only be used on premises that generate per day:
  - (a) a maximum hydraulic loading of 2700L; and
  - (b) a maximum organic loading of 800g BOD<sub>5</sub>
7. For the system to meet the requirements of a greywater treatment system, the system must produce the following effluent quality-
  - (a) BOD<sub>5</sub> – less than or equal to 240 mg/L; and
  - (b) Suspended solids – less than or equal to 140mg/L
8. Each system must be serviced in accordance with the manufacturers details supplied in the owner’s service and maintenance manuals.
9. Each system must be supplied with —
  - (a) a copy of this Treatment Plant Approval document;
  - (b) details of the system and ancillary equipment;
  - (c) instructions for authorised persons for its installation;
  - (d) a copy of the owner’s manual to be given to the owner at the time of installation; and
  - (e) detailed instructions for authorised service personal for its operation and maintenance.
10. This approval does not extend, apply to, or include the land application system used in conjunction with an approved system installed on premises.

11. At each anniversary of the Treatment Plant Approval date, the manufacturer must submit to the Chief Executive a list of all systems installed in Queensland that they have received an installation and commissioning certificate for during the previous 12 months.
12. Where the Chief Executive is notified of any system failures that they believe are a result of poor design or faulty manufacture, the Chief Executive may randomly select a number of installed systems for audit. The Chief Executive will notify the National Association of Testing Agencies (NATA) accredited laboratory nominated by the manufacturer, which systems are to be audited for Biochemical Oxygen Demand (BOD<sub>5</sub>) and Total Suspended Solids (TSS). The sampling and testing of the selected systems, if required, is to be done at the manufacturer's expense. The following results must be reported to the Chief Executive;
  - (a) Address of premises.
  - (b) Date inspected and sampled.
  - (c) Sample identification number.
  - (d) Biochemical Oxygen Demand (BOD<sub>5</sub>).
  - (e) Total Suspended Solids (TSS).
13. The Chief Executive may, by written notice, cancel this approval if the manufacturer fails — to comply with one or more of the conditions of approval; or within 30 days, to remedy a breach, for which a written notice been given by the Chief Executive.
14. This approval may only be assigned with the prior written consent of the Chief Executive.
15. This approval expires on 30 April 2024 unless cancelled earlier in accordance with paragraph 13 above.
16. The amendment to the approval 03/2021 is made on 22 December 2023.



**Anne Neuendorf**  
**Acting Assistant Director General**  
**Building Policy**  
**Department of Housing, Local Government, Planning and Public Works**  
Date approved: 22 December 2023

**TREATMENT PLANT APPROVAL No. 01/2022**  
**Amendment 1**  
*Plumbing and Drainage Act 2018*

**SCHEDULE**

**Attachment 1**

Specifications for the

**Nature Clear GWS10**

## Specifications

---

### What the package includes:

1. 450 Litre Filter tank
2. 100 mm ODV inlet pipe
3. 1 large piece of Fine Geotextile (Black or Beige)
4. 1 small piece of fine Geotextile (Black or Beige)
5. 1 small piece of coarse Geotextile (Black or Beige)
6. 3 x sample bags of gravel & sand

### You will require

1. 100 kg of gravel nominal size 12-25 mm
2. 120 Kg of fine sand of nominal size 0.4-1.2mm
3. 320Kg of coarse sand of nominal size 1.5-3 mm
4. 210 Litres of fine bark

## NATURE-CLEAR GWS10 2.0 GREYWATER TREATMENT SYSTEM

The system provides a simple and low cost effective means of treating greywater. Not only is the equipment low cost, but also, on a suitable site, the only significant excavation work required to install the system will be the trenching. The ongoing costs of the GWS10 will be similar to those of a standard septic system.

In order for the filtration tank to work effectively it is necessary to remove food scraps and grease from the kitchen waste water (see page 7 for further details). For this purpose, we supply a 300L grease trap. As an alternative we can supply smaller grease traps which need more frequent emptying.

The filtration tank, which is less than 1 cubic metre in size, consists of a pine bark coarse filter on top of a fine sand filter.

### The coarse filter removes:

- large particles not caught in the grease trap; and
- lint from the washing machine.

### The sand filter:

- traps still finer particles
- polishes the water; and
- reduces the organic content of the water.

The pine bark is separated from the sand by filtration material. The filtered material and bark will compost over time but should be removed and replaced with fresh bark as per the instructions in the maintenance section of this manual. If your distribution area is downhill from the filtration tank your geotech engineer will be able to design a distribution system without the use of a pump. If this is not the case, you will need a pump well. If required, we recommend that the well and pump are purchased locally from your plumbing store. General instructions on how to install a pump are provided in this manual.

The water that exits in the filtration tank is classified as having undergone "Primary Treatment" and must be distributed into trenches as specified by your engineer. Make sure their size calculation does not include an allowance for toilet water, which would make the trenches unnecessarily large and expensive

GWS10 Filtration Tank





# GWS10

## FILTRATION TANK INSTALLATION

---

The filtration tank should be at least partially dug (at least 500mm deep) into the ground. The tank should be laid on a bed of sand with a 1-2% incline towards the outlet pipes.

The tank is first filled with 5 - 6 x 20kg bags of gravel (River sands Resources #3 gravel or similar with a nominal size of 12-25 mm). The gravel must be no smaller than this. The layer should be at least 80mm thick and cover the outlet pipe. Rake the gravel flat. Be careful not to damage the outlet pipes as the gravel is added.

Lay the larger fine black or beige coloured filter cloth material on top of the gravel such that the 100mm slots in the material are located above the 100mm inlet pipe. The material should hang over the sides (see page over).

Carefully add 120kg of fine grade washed sand (Riversands 7C sand or similar with a nominal size of 0.4-1.2mm). The fine sand layer should be about 100 mm thick. Rake the sand flat. Then add 320 kg of coarse washed sand (Riversands #6 sand or similar with nominal size of 1.5-3.0 mm). Rake flat.

**Note:**

**We strongly recommend that the sand is washed before putting it into the tank by placing it on the filtration material and allowing water to flow thru to remove the fines from the sand. If the sand is not washed until the fines have been removed they will end up further down the system with the possibility of causing expensive blockages.**

The smaller, fine black or beige coloured filtration material is then positioned to lie flat on top of the sand and then add half of the medium coarse pine bark 160 litres. The top of the shade cloth is designed to extend beyond the top of the tank for ease of removal when the material needs to be cleaned. The 'U' shaped slots in the top of the shade cloth are for fitting around the inlet pipe. Lay the coarse green coloured filtration material on top of half of the bark just below the inlet pipe and fill the tank with the rest of the bark.

Connect the outflow from the grease trap (if kitchen water is being diverted into your Nature-Clear) and other waste water sources to the inlet pipe of the tank ensuring that the inlet pipe is sealed where it enters the tank. Also seal the opposite end of the inlet pipe where it exits the tank. The screw cap end should be on the same end of the tank as the Outlets at the base of the tank.

If the application area is to be gravity fed the 2 outlet pipes from the filtration tank will now need to be connected to the pipe work of the application area.

# NATURE-CLEAR GWS10 FILTRATION TANK SPECIFICATIONS

## FILTRATION TANK:

- Material; Medium density grade polyethylene
- Properties; U. V stabilised - High stress resistance
- Thickness; Average 5 mm
- Construction;
  - Rotational moulding
  - All surfaces are continuous with no welded or joined seams
  - Ribbed structure for additional strength
- Dimensions;
  - Height: 780 mm
  - Length: 940-1025 mm
  - Width: 820-910 mm

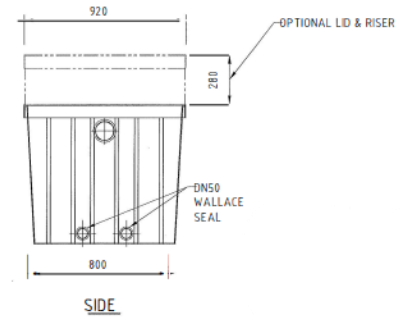
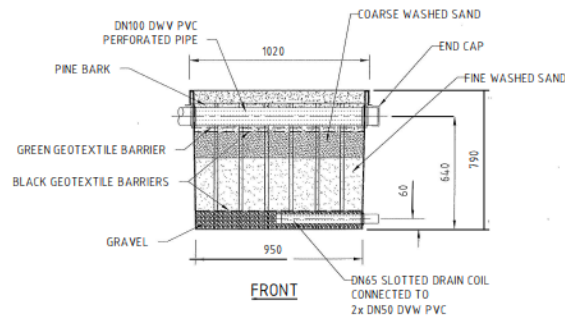
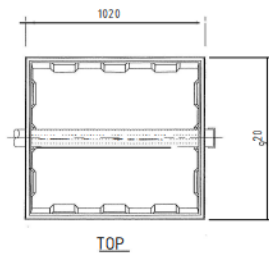

### NOTES:

1. MANUFACTURING TOLERANCE  $\pm 2\%$ .
2. ALL MATERIAL LDPE EXCEPT PVC PIPING AND S/S FASTENERS.
3. TANK CONTENT: **NOT SUPPLIED**
  - 3.1. 100kg GRAVEL OF NOMINAL SIZE 12-25mm.
  - 3.2. 100kg FINE SAND OF NOMINAL SIZE 0.4-1.2mm.
  - 3.3. 300kg SAND OF NOMINAL SIZE 1.5-3.0mm.

PRELIMINARY  
NOT FOR CONSTRUCTION

				UNLESS OTHERWISE STATED ALL DIMENSIONS IN mm						PH 1300 136 182 www.ecoflo.net.au ABN 33 606 583 895		CONSULTANT : <b>NEUBAU</b> <small>www.neubau.com.au PH (07) 3202 1244</small>		A3
								CLIENT : <b>ECOFLO WASTEWATER MANAGEMENT</b>						SHEET
								JOB TITLE : <b>NATURE CLEAR GWS10</b>						1
								DWG TITLE : <b>GREY WATER PREFILTER 450 L ARRANGEMENT AND DETAILS</b>						OF
								SCALE: <b>1:20</b>						1
								DRAWN BY: <b>HN</b>						REV
								DATE : <b>14.3.16</b>						C
								DESIGNED:						
								APPROVED:						
								DRAFTING STANDARD AS 1100						
								DWG FILE NAME:						
								SUB DR -- DR -- DATE -- BY --						
								JOB No:						
								DWG No:						
								ECO-301-G-01						
								DATE:						
								BY:						

REV	DESCRIPTION	CHKD	DATE	BY
C	REVISED DRAIN PIPE	PV	28.4.16	HN
B	ADDED NOTES AND OPTIONAL RISER	PV	26.4.16	HN
A	PRELIMINARY ISSUE		14.3.16	HN

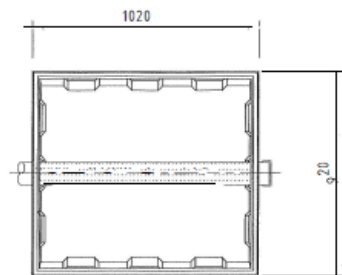

TOP

NOTES:

1. MANUFACTURING TOLERANCE ±2%.
2. ALL MATERIAL LDPE EXCEPT PVC PIPING AND S/S FASTENERS.
3. TANK CONTENT: <NOT SUPPLIED>
  - 3.1. 100kg GRAVEL OF NOMINAL SIZE 12-25mm.
  - 3.2. 100kg FINE SAND OF NOMINAL SIZE 0.4-1.2mm.
  - 3.3. 300kg SAND OF NOMINAL SIZE 1.5-3.0mm.

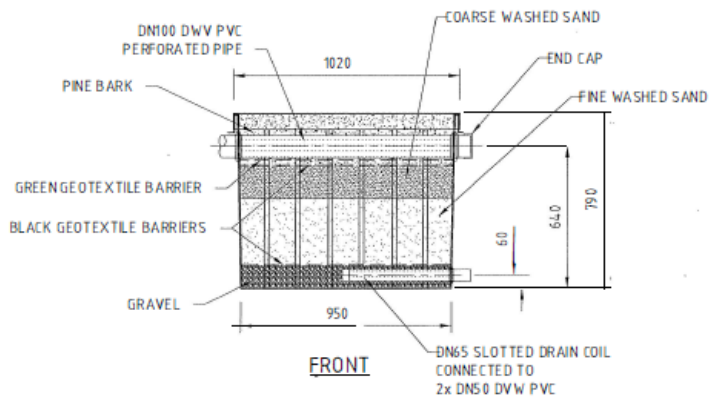

FRONT

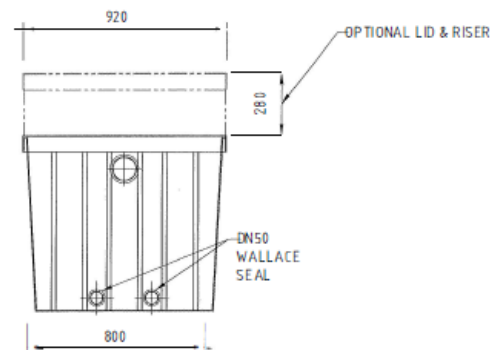

SIDE

PRELIMINARY  
NOT FOR CONSTRUCTION

				UNLESS OTHERWISE STATED ALL DIMENSIONS IN mm			 wastewater management		PH 1300 138 182 www.ecoflo.net.au AIN 33 606 583 895		CONSULTANT : <b>NEUBAU</b> <small>project management   engineering</small> www.neubau.com.au PH (07) 3282 1244		CLIENT : <b>ECOFLO WASTEWATER MANAGEMENT</b>		<b>A3</b>
				 THIRD ANGLE PROJECTION DRAFTING STANDARD AS 1100			DRAWN BY: <b>HN</b>		DESIGNED:		APPROVED:		JOB TITLE : <b>NATURE CLEAR GWS10</b>		SHEET 1 OF 1
							DATE : <b>14.3.16</b>		DATE : -		DATE : -		DWG TITLE : <b>GREY WATER PREFILTER 450 L ARRANGEMENT AND DETAILS</b>		
							SCALE: <b>1:20</b>		JOB No: -		DWG No: <b>ECO-301-G-01</b>		REV <b>C</b>		
							DATE FILE NAME: - SUB DIR - DIR - DATE - BY: -								
REV	DESCRIPTION	CHKD	DATE	BY											
C	REVISED DRAIN PIPE	PV	28.4.16	HN											
B	ADDED NOTES AND OPTIONAL RISER	PV	26.4.16	HN											
A	PRELIMINARY ISSUE		14.3.16	HN											